

RESEARCHES ON THE ROTARY VALVES OF THE HYDRAULIC STEERING SYSTEMS

L. N. VASILE, N. VASILIU, C. CĂLINOIU*

Lucrarea prezintă cercetările întreprinse de autori asupra caracteristicilor de regim staționar ale distribuitorilor hidraulice rotative cu centrul deschis, utilizate în sistemele hidraulice de direcție ale automobilelor moderne. În scopul validării modelelor matematice propuse, autorii au conceput și realizat un stand dedicat determinării sensibilității în presiune a distribuitorilor de acest tip. În cadrul lucrării este prezentată metodologia de încercare și rezultatele experimentale obținute pentru o servodirecție Volvo ZF Servotronic.

The paper presents the researches carried out by the authors on the steady-state behaviour of the open centre, flow control valves, included in the hydraulic steering systems of the modern cars. A test bench was designed, in order to validate the theoretical models of the valves, and to find out the pressure sensitivity. The paper contains the test procedure and the experimental results obtained by testing a Volvo ZF Servotronic hydraulic steering.

Keywords: hydraulic steering, rotary flow control valve, valve coefficients, test procedures.

Introduction

Researches on the steady-state characteristics of the flow control valves are fundamentally related to the overall system dynamics (e.g. steering system). From the control systems theory point of view, the main non-linearity of the hydraulic valves is the flow - opening steady state characteristics. Establishing the appropriate values for the valve coefficients is the most important step in the dynamics approach of a hydraulic control system.

This paper is an useful tool for the identification of the geometric and design parameters of the flow control valves included in power steering systems. At the same time, it provides a trustworthy experimentally validated mathematical model for computing certain parameters and coefficients useful in valve design and power steering design.

*Ph.D. Student; Prof.; Prof.; Dep. of Hydraulics and Hydraulic Machines, Faculty of Power Engineering, University POLITEHNICA of Bucharest, Romania

1. Theoretical approach

In order to create a realistic model for determining the pressure sensitivity of the rotary flow control valve (Fig. 1) and because of the rotary valve complexity, certain assumptions were taken:

- the ports to the hydraulic cylinder are closed (or the cylinder rod is locked);
- the metering orifices corresponding to one way of the valve were reduced to a single equivalent orifice;
- the angular relative displacement between the spool and the sleeve was converted into a linear displacement, measured on the contact diameter between the two components;
- for small openings of the valve (inside the underlap operating domain), the flow area varies linearly with the valve opening;
- the flow coefficient of the equivalent orifices is constant.

In Fig. 2, the equivalent computational diagram for the valve is presented. Taking into account the above assumptions, and considering a constant supply flow valve, the following equations can be written:

$$Q_m = c_d \cdot b_l \cdot (U + x) \cdot \sqrt{\frac{2(p_s - p_A)}{\rho}} - c_d \cdot b_l \cdot (U - x) \cdot \sqrt{\frac{2(p_s - p_B)}{\rho}} = 0 \quad (1)$$

$$Q_s = c_d \cdot b_l \cdot (U + x) \cdot \sqrt{\frac{2(p_s - p_A)}{\rho}} + c_d \cdot b_l \cdot (U - x) \cdot \sqrt{\frac{2(p_s - p_B)}{\rho}} \quad (2)$$

Here Q_m is the flow fed to the hydraulic cylinder (null flow); Q_s – the constant supply flow; c_d – flow coefficient of the equivalent metering orifices; b_l – area gradient inside the underlap operating domain; U – valve underlap; x – valve opening; p_s – pressure inside the valve supply line; p_A – A cylinder port pressure; p_B – B cylinder port pressure; ρ – fluid density.

Summing the above two equations, and taking into account the basic relation [1...7],

$$p_s = p_A + p_B \quad (3)$$

one can find the pressure variations inside the cylinder chambers as functions of the valve opening (Fig. 3):

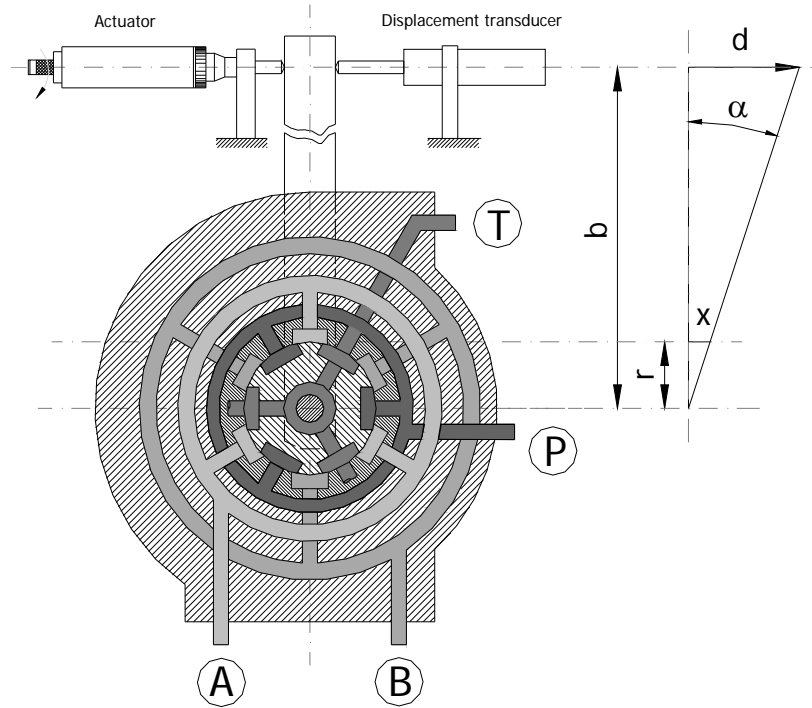

Fig. 1. Cross section through the tested flow control valve

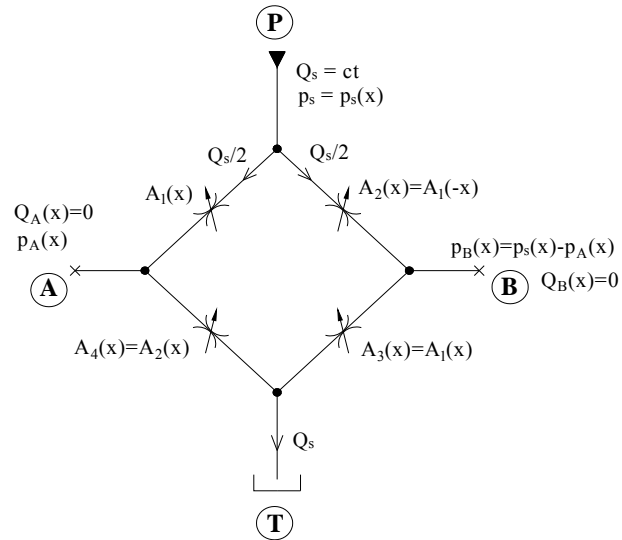

Fig. 2. Equivalent computational diagram of the valve (the cylinder ports are closed)

$$p_A = \frac{\rho \cdot Q_s^2}{8 \cdot c_d^2 \cdot b_I^2 \cdot (U - x)^2} \quad (4)$$

$$p_B = \frac{\rho \cdot Q_s^2}{8 \cdot c_d^2 \cdot b_I^2 \cdot (U + x)^2} \quad (5)$$

and their derivatives,

$$p_A'(x) = \frac{\rho \cdot Q_s^2}{4 \cdot c_d^2 \cdot b_I^2} \cdot \frac{1}{(U - x)^3} \quad (6)$$

$$p_B'(x) = -\frac{\rho \cdot Q_s^2}{4 \cdot c_d^2 \cdot b_I^2} \cdot \frac{1}{(U + x)^3} \quad (7)$$

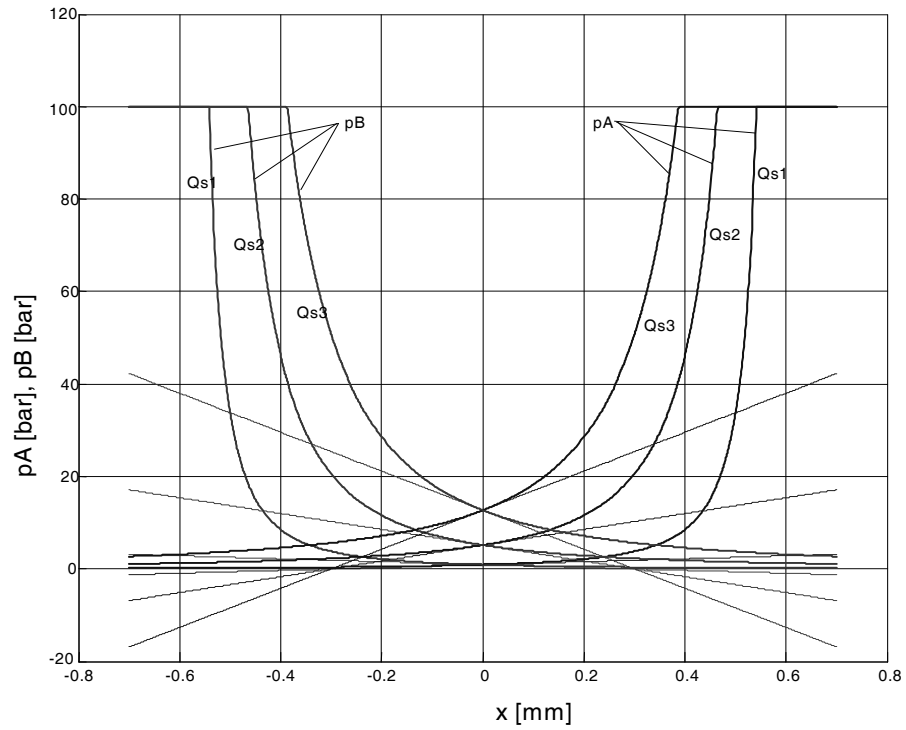

Fig. 3. The computed pressure variation with respect to the valve opening, for different supply flows ($Q_{s1} < Q_{s2} < Q_{s3}$)

The supply pressure variation law due to the valve opening is obtained by summing the pressures inside the cylinder ports:

$$p_s = \frac{\rho \cdot Q_s^2}{4 \cdot c_d^2 \cdot b_l^2} \cdot \frac{U^2 + x^2}{(U+x)^2 (U-x)^2} \quad (8)$$

The pressure drop across the cylinder becomes:

$$P_m = p_A - p_B = \frac{\rho \cdot Q_s^2}{2 \cdot c_d^2 \cdot b_l^2} \cdot \frac{U \cdot x}{(U+x)^2 (U-x)^2} \quad (9)$$

The valve pressure sensitivity, K_{Px} is defined as the derivative of the pressure drop across the hydraulic motor, with respect to the valve opening around the hydraulic null of the valve. By differentiating equation (9) around the zero opening position of the valve, one may get:

$$K_{Px} = \left. \frac{\partial P_m}{\partial x} \right|_0 = \frac{\rho \cdot Q_s^2}{2 \cdot c_d^2 \cdot b_l^2 \cdot U^3} \quad (10)$$

For a centred valve spool, the supply pressure of the servomechanism is:

$$p_{s0} = \frac{\rho \cdot Q_s^2}{4 \cdot c_d^2 \cdot b_l^2 \cdot U^2} \quad (11)$$

So, the pressure sensitivity becomes:

$$K_{Px} = \left. \frac{\partial P_m}{\partial x} \right|_0 = \frac{2 \cdot p_{s0}}{U} \quad (12)$$

2. Experimental results

The experiments were performed on a ZF Servotronic hydraulic power steering, used on VOLVO cars [17]. The test bench general view is presented in fig 4. The tested power steering was mounted on a metallic structure, having the cylinder rod fully mechanically constrained. The system was supplied at constant flow from an external hydraulic power source, having the possibility to set the flow value. Pressure transducers were mounted on each hydraulic port of the valve, in order to find out the pressure variation as a function of the valve opening. An actuation rotary lever amplified the valve opening as a steering wheel. The adjustment of the lever position was done by a fine thread screw. The displacement from the zero opening position was measured by a displacement transducer connected to a data acquisition system supplied by KEITHLEY Corporation.

A typical family of curves, corresponding to different values of the supply flow is presented in Fig. 5. The maximum pressure in the system was limited by a high quality two-stage safety valve at the value of 80 bars.

By comparing the theoretical and the experimental curves, one can see some differences in pressure variation, which may be explained by reconsidering the assumptions taken in developing the mathematical model only.

After investigating the error introduced by the initial assumption, it was found that the difference between the two curves might be reasonably explained by a variable flow coefficient of the valve with respect to its opening for an well-determined area variation of the metering orifices. This flow coefficient variation mainly depends on the studied power steering. In Fig. 6, one can see the comparison between the theoretical and experimental curves in the case of the nominal flow supply.

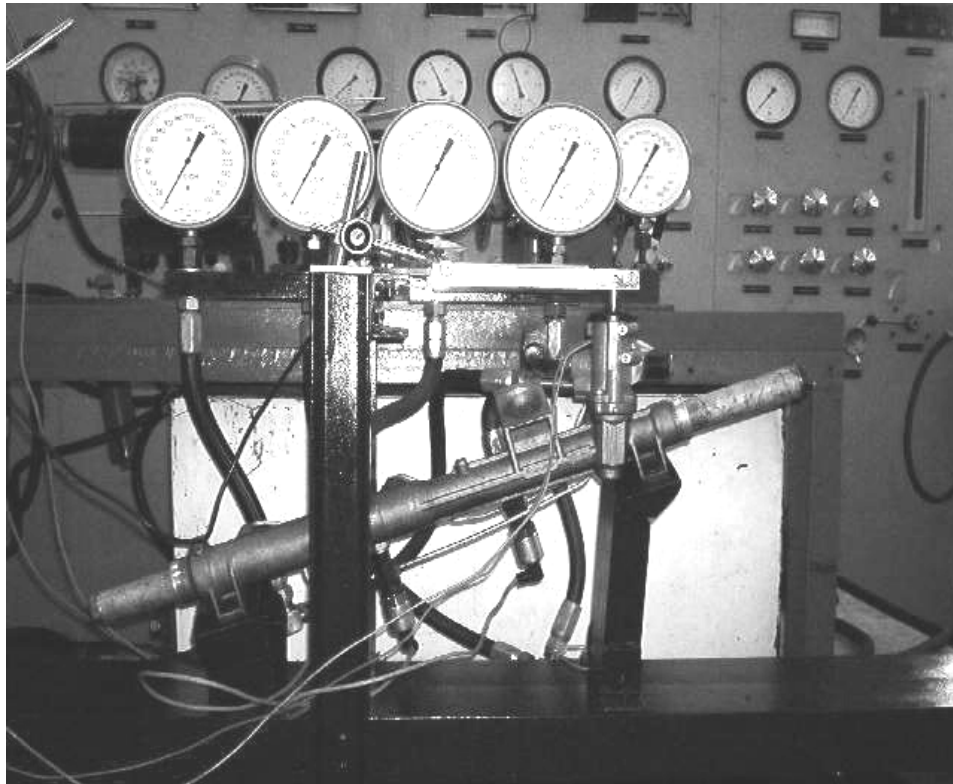

Fig. 4. Front view of the experimental test bench
(in front – the power steering with the actuation system;
in background – the hydraulic constant flow supply source)

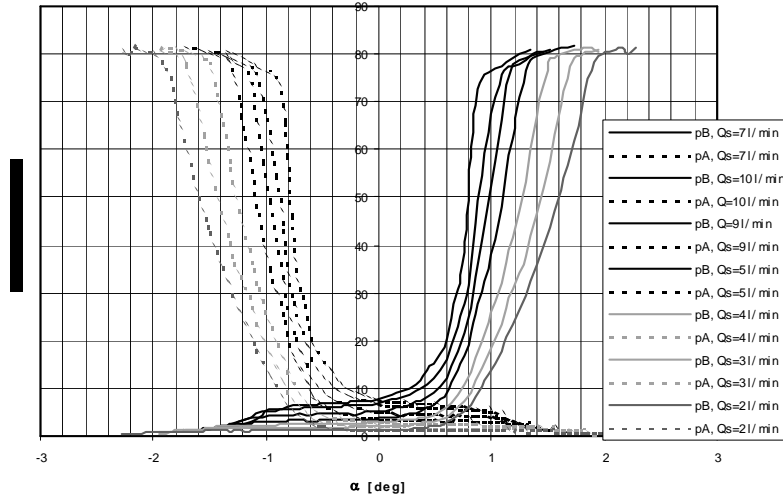

Fig. 5. Pressure variation inside the cylinder chambers, with respect to the valve opening for different supply flows (locked cylinder rod)

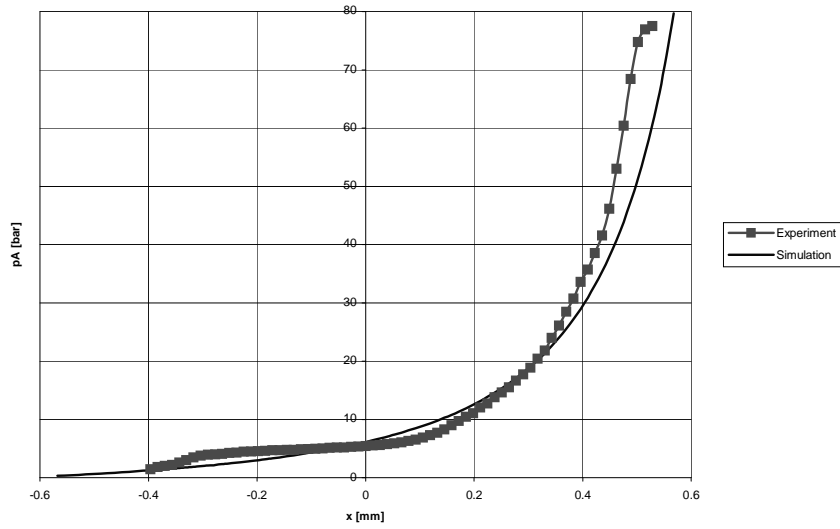

Fig. 6. Pressure variation with respect to the valve opening for nominal supply flow

Conclusions

The pressure sensitivity of a flow valve is of great importance, because it represents the major uncertain quantity needed in designing a hydraulic control system by a compromise between the stability and the precision.

The paper is useful as a tool in designing hydraulic systems equipped with open centre flow control valves (mainly hydraulic power steering systems) because it provides a realistic mathematical model for computing the valve parameters and coefficients. At the same time, the paper presents a simple methodology for the steady-state identification of the open centre flow control valves, used in the preliminary design stage by all the manufacturers [8...17].

REFERENCES

1. *J.F. Balckburn, G. Reethof, J. Sharer*, Fluid Power Control, John Wiley & Sons Inc., 1960
2. *Călinoiu C., Vasiliu D., Vasiliu N.*, Modelarea, simularea și identificarea experimentală a servomecanismelor hidraulice, Editura Tehnică, 1998.
3. *Oprean, I.M.*, Automobilul modern, Editura Academiei Române, 2003.
4. *N. Vasiliu, D. Vasiliu*, Acționări hidraulice și pneumatice, Vol. 1, Editura Tehnică, București, 2005
5. *T.J. Viersma*, Analysis, Synthesis and Design of Hydraulic Servosystems and Pipelines, Elsevier Scientific Publishing Company, Amsterdam, 1980
6. *J. Birsching*, Two Dimensional Modeling of a Rotary Power Steering Valve, SAE 2001 World Congress Detroit, Michigan, March 5-8, 2001
7. *H. E. Merrit*, Hydraulic Control Systems, John Wiley & Sons Inc., 1967
8. *Reuter, D., Lloyd, E., Zehnder W. II, Elliott, A.*, Hydraulic Design Considerations for EHB Systems, SAE Technical Paper, 2003.
9. *Beyer K., Krueger E., Sonnenberg, M.*, Enhanced Vehicle Stability with Engine Drag Control, SAE Technical Paper, 2002.
10. *Roberts S., Day T.*, A Simulation Model for Vehicle Braking Systems Fitted with ABS, SAE Technical Paper, 2002.
11. *Roberts S., Day, T.*, Integrating Design and Virtual Test Environments for Brake Component Design and Material Selection, SAE Technical Paper, 2000.
12. *Ono, E., Asano K., Sugai M., Ito, S.*, Estimation of Friction Force Characteristics Between Tire and Road Using Wheel Velocity and Application to Braking Control, SAE Technical Paper, 2000.
13. *** *VCC*, Braking Systems - Design and Function, 2004.
- *** *DAS-1600/1400 Series - User' Guide*. Keithley Metrabyte Division, Taunton, MA, 1994.
14. *Continental Teves*, New Generation of Braking Systems, 2004.
15. *Delphi Corporation*, New Braking Systems, 2004.
16. *Bosch*, EHB Braking System, 2004.
17. *ZF Hydraulic steering systems specification*, Friederikshafen - <http://www.zf-lenksysteme.com/>